

**UCOM**

**COCOON 910**

**CORDLESS PHONE**



**USER GUIDE**  
**1.3**



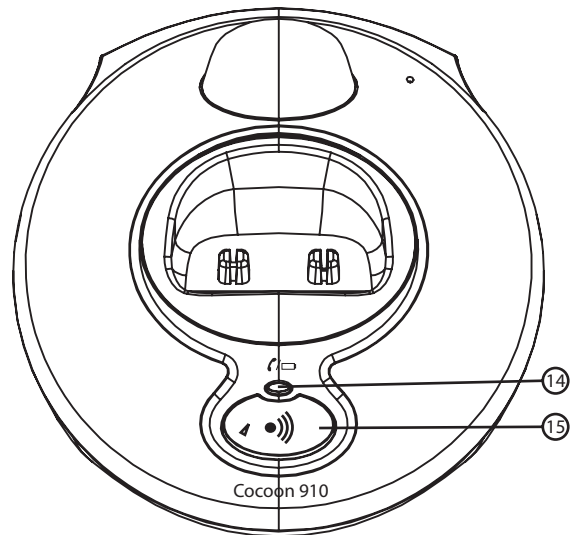
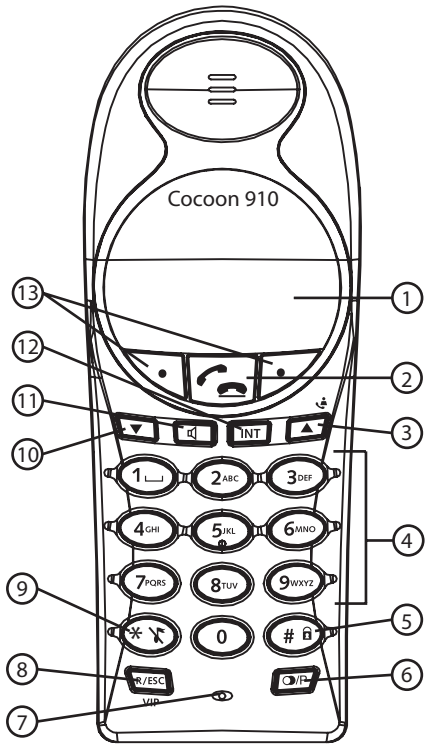

## Before Initial use

Thank you for purchasing this new digital cordless telephone

### Intended Purpose:

This product is intended to be connected indoor to an analogue telephone line. You have acquired a Cocoon 910, which is a product made in accordance with the Digital Enhanced Cordless Telecommunications (DECT). DECT technology is characterized by high-security protection against interceptions as well as high-quality digital transmission. This telephone was designed for a wide range of applications. For example, this telephone can be used within a network of base units and handsets, constituting a telephone system which:

- Operates up to 5 handsets at one base unit.
- Allows an intercom between 2 handsets.
- Allows the operation of a handset at up to 4 base units.

Caller ID is a network provider service. After subscribing to Caller ID, this phone will display the caller's phone number.

### Important

To use 'Caller ID' (display caller), this service has to be activated on your phone line. Normally you need a separate subscription from your telephone company to activate this function. If you don't have the Caller ID function on your phone line, the incoming telephone numbers will NOT be shown on the display of your telephone.

The CE symbol indicates that the unit complies with the essential requirements of the R&TTE directive.

The features described in this manual are published with reservation to modifications.

<b>1</b>	<b>Safety advice</b>	<b>5</b>
<b>2</b>	<b>Cleaning</b>	<b>6</b>
<b>3</b>	<b>Disposal of the device (environment)</b>	<b>6</b>
<b>4</b>	<b>Installation</b>	<b>7</b>
4.1	Installing the base	7
4.2	Installing the batteries	8
<b>5</b>	<b>Getting to know your telephone</b>	<b>9</b>
5.1	Keys/LED	9
5.2	Navigating the menu	10
<b>6</b>	<b>Handset operation</b>	<b>11</b>
6.1	Turning the handset on / off	11
6.2	Setting the language	11
6.3	Making Calls	11
6.4	Receiving a Call	12
6.5	Redial list options	13
6.6	Activate/deactivate handsfree function	13
6.7	Out of range warning	13
6.8	Setting the speaker volume	13
6.9	Call Duration Indicator on the Display	14
6.10	Turning off the microphone (mute)	14
6.11	Pause key	14
6.12	Locating a misplaced handset (paging)	14
6.13	Using the alphanumeric handset keypad	14
6.14	Setting the ring volume level on the handset	15
6.15	Setting the ringer melody on the handset	16
6.16	Locking the key pad	16
6.17	Turning key click ON/OFF	17
6.18	Display contrast	17
6.19	Changing the handset name	17
6.20	Auto answer	17
<b>7</b>	<b>Default handset settings (Handset reset)</b>	<b>18</b>
<b>8</b>	<b>Setting the clock and alarm</b>	<b>18</b>
8.1	Date and time	18
8.2	Hour format	19
8.3	Using the alarm feature	19
<b>9</b>	<b>The phone book</b>	<b>19</b>
9.1	Adding a number and a name to the phone book	19
9.2	Looking up a number in the phone book	20
9.3	Changing a name or number in the phone book	20
9.4	Deleting name and number from the phone book	20
<b>10</b>	<b>VIP list</b>	<b>20</b>
10.1	Copy phonebook entries to the VIP list	20
10.2	Changing a ring tone for a VIP entry	21
10.3	Deleting an entry from the VIP list	21

<b>11</b>	<b>Base operation</b>	<b>21</b>
11.1	Setting the ring volume and melody of the base	21
11.2	The R key (flash)	22
11.3	Changing the PIN code (system pin code)	22
11.4	Setting the dialling mode	22
<b>12</b>	<b>Additional handsets and bases</b>	<b>23</b>
12.1	Adding a new handset	23
12.2	Removing a handset	23
12.3	Selecting a base unit	24
12.4	Using multiple handsets	24
<b>13</b>	<b>Caller ID/CLIP</b>	<b>25</b>
13.1	The Call List	26
13.2	Calling a number from the Call List	26
13.3	Storing a number from the Call List in the Phone Book	26
13.4	Deleting numbers from the Call List	26
<b>14</b>	<b>Voice mail indicator</b>	<b>27</b>
<b>15</b>	<b>Menu structure</b>	<b>27</b>
<b>16</b>	<b>Trouble shooting</b>	<b>28</b>
<b>17</b>	<b>Technical characteristics</b>	<b>28</b>
<b>18</b>	<b>Warranty</b>	<b>29</b>
18.1	Warranty period	29
18.2	Warranty handling	29
18.3	Warranty exclusions	29
<b>19</b>	<b>Service address and support</b>	<b>29</b>
<b>20</b>	<b>Declaration of Conformity and manufacturer</b>	<b>29</b>

## 1 Safety advice

The following safety advice must always be followed before using electrical equipment. Please read carefully through the following information concerning safety and proper use. Make yourself familiar with all the functions of the equipment. Be careful to keep these advice notes and if necessary pass them on to a third party.

### Electrical safety and protection:

- Do not operate the equipment if the mains plug, cable or the equipment itself is damaged.
- If the equipment is dropped, then it must be checked by an electrician before further use.
- Dangerous voltages are present inside the equipment. Never open the housing or insert objects through the ventilation holes.
- Do not allow liquids to get into the equipment. In case of emergency, pull out the plug from the socket.
- Similarly, if a fault develops during use or before you start to clean the equipment, pull the plug out if the socket.
- Do not touch the charger and plug contacts with sharp or metal objects.
- Do not carry out any modifications or repairs to the equipment yourself. Have repairs done to the equipment or the mains cable only by a specialist service centre. Unsatisfactory repairs can lead to considerable danger for the user.
- Children frequently underestimate the dangers associated with electrical equipment. Therefore you must never leave children unsupervised in the vicinity of electrical equipment.
- The equipment is not to be used in a damp room (e.g. bathrooms) or rooms where there is a lot of dust.
- Equipment connected to the mains during a thunderstorm can be damaged by lightning. Therefore you should pull the plug out of the mains socket during a storm.
- To completely disconnect the equipment from the electricity supply, the plug must be removed from the socket. When doing this always pull on the plug itself and never on the cable.
- Protect the mains cable from hot surfaces or other sources of damage and do not allow it to become constrained.
- Check the mains cable regularly for any damage.
- Unwind the mains cable completely before use.
- Make sure that the mains cable does not represent a trip hazard.
- The operation of some medical devices may be affected.
- The handset may cause an unpleasant buzzing sound in hearing aids.

### Fire safety:

- The heat accumulated inside the equipment can lead to the defect and/or to the fire of the equipment. Do not expose this equipment therefore to extreme temperature like:
  - direct sun exposure and heater warmth
  - ventilation holes may not be covered

**Danger of explosion:**

- Never throw batteries in fire.

**Poisoning danger:**

- Keep batteries away from small children.

**Note:**

- Only use the charger plug supplied. Do not use other chargers, as this may damage the batteries cells.
- The wall outlet for the power supply must be close and accessible
- As this telephone cannot be used in case of a power cut, you should use a mains-independent telephone for emergency calls, e.g. a mobile phone.
- Only use rechargeable batteries of the same type. Place the batteries with correct polarity inside the battery compartment (polarity is marked inside the handset). Never use normal un rechargeable batteries!

## 2 Cleaning

Clean the telephone with a slightly damp cloth or with an anti-static cloth. Never use cleaning agents or abrasive solvents.

## 3 Disposal of the device (environment)



At the end of the product lifecycle, you should not throw this product into the normal household garbage but bring the product to a collection point for the recycling of electrical and electronic equipments. The symbol on the product, user guide and/or box indicate this.

Some of the product materials can be re-used if you bring them to a recycling point. By re-using some parts or raw materials from used products you make an important contribution to the protection of the environment.

Please contact your local authorities in case you need more information on the collection points in your area.

## 4 Installation



Before you use the telephone for the first time, you must first make sure the battery is charged. If you do not do this, the telephone will not work optimally.

### 4.1 Installing the base

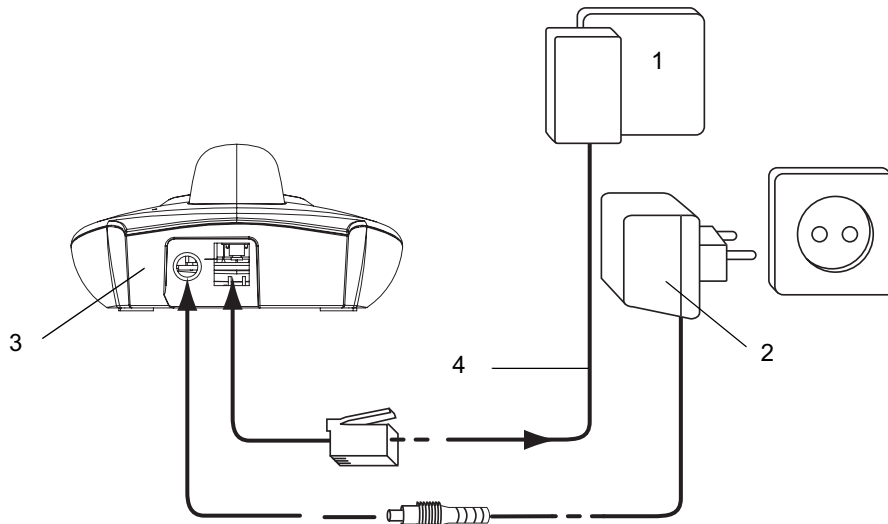

For installation, do the following:

- Plug one end of the adaptor into the outlet and the other end into the adapter jack on the back of the base.
- Connect one end of the telephone cord with the wall phone jack and the other end to the back of the base.







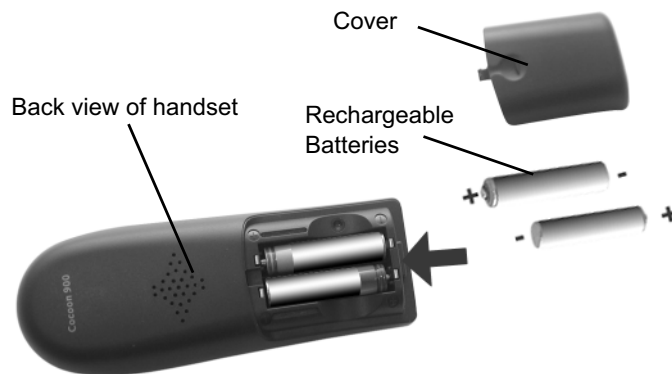

1. Telephone wall outlet
2. Power cable
3. Back view of BASE
4. Telephone cord

## 4.2 Installing the batteries

- Open the battery compartment (see below).
- Insert the batteries **respecting the (+ and -) polarity**.
- Close the battery compartment.
- Leave the handset on the base unit for 20 hours. The Line/Handset indicator  (LED)  on the base unit will light up.



### Battery indicator:

-  The battery is fully charged.
-  The battery is 25% drained
-  The battery is half drained (50%)
-  The battery is 75% drained
-  The battery is low. When the battery is low, you will hear warning signals and the battery symbol  on the display will blink.

## 5 Getting to know your telephone

### 5.1 Keys/LED

#### Handset

1. Display
2. Line key
3. Up/Call log key
4. Alphanumeric keys
5. Keypad Lock Key
6. Redial/Pause key
7. Microphone
8. Flash/Escape/VIP Key
9. Ringer volume Off
10. Down Key
11. Handsfree Key
12. Internal Key INT
13. Option/Softmenu Keys

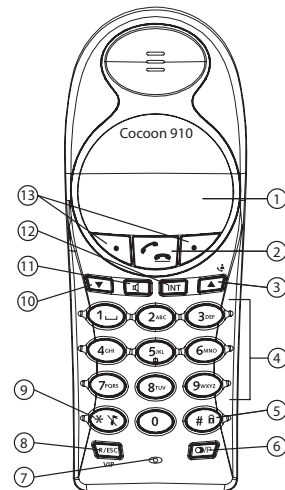

#### Base



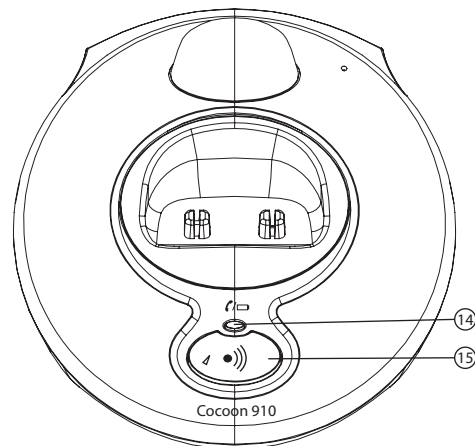



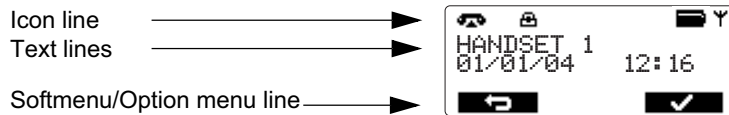













14. Line/Handset in base indicator
15. Paging key



#### Display (LCD)



## Icons

	On hook
	Off hook
	Ringing
	Internal call
	Internal communication between 2 handsets
	Handsfree speaker ON
	Keypad locked
	Upper case
	Lower case
	Possible scroll direction
	Unread call log entry
	Read call log entry
	Call log entries (steady) New unanswered calls (blinking)
	Voice mail message
	Handset ringer off
	Alarm set
	VIP list
	In range (steady) Out of range (blinking)
	External line on hold
	Internal line on hold

## 5.2 Navigating the menu

The handset has a menu system which is easy to use. Each menu leads to a list of options. The menu map is shown in "15 Menu structure".

When the handset is switched On and in standby, press the option button under '**Menu**' (13) to open the main menu.

Press the ▲ (3) or ▼ (10) button to scroll to the menu option you want. An arrow ► -icon shows the menu item you have selected. Then press  (13) to select further options or confirm the setting displayed.







**Exit or go back one level in the menu:**

To go to the previous level in the menu, press  (13).

To cancel and return to standby at any time, press the **ESC** (8) key. If no button is pressed for 15 seconds, the handset returns to standby automatically.











**6 Handset operation****6.1 Turning the handset on / off**

- To turn the handset On, press the line key  (2).
- To turn the handset Off, press the option button under 'Menu' (13) and then use the arrow keys  (3) or  (10) until "Power off" is selected. Press  (13) to confirm or  (13) to leave the menu.





**6.2 Setting the language**

The telephone has 5 display languages: see display languages table on packaging box!!





To set the language, do the following:

- Press the option button under 'Menu' (13)
- Press the Up or Down key  (3)/ (10) repeatedly until "Handset" is selected
- Press  (13) to confirm
- Press the Up or Down key  (3)/ (10) repeatedly until "Language" is selected
- Press  (13) to confirm
- The language set appears on the display.
- Press the Up or Down key  (3)/ (10) repeatedly to select the language you would like to use.
- Press  (13) to confirm your selection or press  (13) to leave the menu.

**6.3 Making Calls****6.3.1 External Call**



- Press the Line key  (2).
- The Line/Handset indicator  (LED) (14) on the base unit will blink and the Call symbol  appear on the display.
- You will hear the dial tone. Dial the telephone number you wish to call.
- The number appears on the display and is dialed.
- After finishing your call, press the Line key  (2) to hang up.

**6.3.2 Number preparation**





- Dial the telephone number you wish to call. You can correct the number by pressing the  (13) key.
- Press the Line key  (2).
- The Line/Handset indicator  (LED) (14) on the base unit will blink and the Call symbol  appear on the display.

- The telephone number is dialled automatically.
- After finishing your call, press the Line key  (2) to hang up.

### **6.3.3 Redialling the last number dialled**





- Press the Line key  (2).
- Press the Redial key  (6). The number you last called is dialled automatically.

### **6.3.4 Redial one of the last 5 numbers dialled**

- Press the Redial key  (6). The number you last called appears on the display.
- Press the Redial key  (6) a few times until the desired number appears on the display.
- Press the Line key  (2).
- The number shown on the display is dialled automatically.
- After finishing your call, press the Line key  (2) to hang up.



### **6.3.5 Calling a programmed number from the Phone Book**

The telephone has a Phone Book in which you can store telephone number with name (See also § "9 The phone book" ). To call a number from the Phone Book:



- Press the Phone Book key  (13). The first number of the Phone Book appears on the display.
- Press the Up or Down key  (3) /  (10) repeatedly to select the telephone number you want to call.
- Press the Line key  (2).
- The number shown on the display, is dialled automatically.
- After finishing your call, press the Line key  (2) to hang up.

## **6.4 Receiving a Call**

During internal or external incoming call, the handset will start to ring. You can temporarily disable the handset ringing by pressing the option key 'Quiet' (13).

- All subscribed handsets will ring when you receive a call.
- The Call symbol  blinks on the display.
- The telephone number of the caller appears on the display if you have Caller ID service (CLIP). Consult your telephone company. The name of the caller also appears on the display if:
  - the number is programmed into the Phone Book with name
  - the network sends the name together with the telephone number
- Press the Line key  (2) to accept the external call.



OR

- Lift the handset off its base (if the Auto answer option is active, See § "6.20 Auto answer")
- During the conversation the  symbol appear on the display and the call timer starts to run.
- After finishing your call, press the Line key  (2) to hang up or put the handset back on the base unit.

## 6.5 Redial list options

When scrolling through the redial list (see §“6.3.4 Redial one of the last 5 numbers dialed”) you have the following options:

When the desired number is shown on the display press ‘Option’ (13) and select with the up and down keys ▲ (3)/▼ (10) the following options:

- **Delete Call:** to delete an entry in the redial list. Press  (13) to confirm.
- **Save number:** to store the number into the phone book memory. Press  (13) to confirm. Enter a name (See §“9.1 Adding a number and a name to the phone book”) and press ‘Save’ (13). Edit the number and press ‘Save’ (13) again.
- **Delete all calls:** to delete all entries in the redial list. Press  (13) to confirm.

## 6.6 Activate/deactivate handsfree function

This function allows you to communicate without having to pick up the handset. When you are talking, press the Handsfree key  (11) to activate the handsfree function.

Press the  (11) button again to deactivate the handsfree function.





**When you are calling in handsfree mode and you want to change the volume, press Up or Down key ▲ (3)/▼ (10) repeatedly.**



**When you use the handsfree function for a long time, the batteries will drain quickly !**

## 6.7 Out of range warning

If the handset is out of range of the base unit, a warning signal will sound.

- ‘SEARCHING’ appears on the display and the symbol  blinks on the display.
- Move closer to the base unit.
- As soon as you are back within range of the base unit, a signal sounds and the symbol  stops blinking.

## 6.8 Setting the speaker volume

Use the Up and Down keys ▲ (3)/▼ (10) during conversation to set the volume of the speaker. You can select from 5 levels. The telephone is set to level ‘3’ by default:

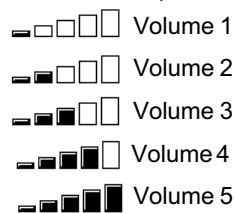

**The handsfree volume can be set the same way as above!**

### 6.9 Call Duration Indicator on the Display

During an external call, the call duration is shown on the display:

E.g. "01:10:40" for 1 hour , 10 minute and 40 seconds.

The call duration remains visible on the display for 5 seconds after each call.

### 6.10 Turning off the microphone (mute)

To turn off the microphone during a call press the option key 'Mute' (13). Now you can speak freely without the caller being able to hear you. To activate the microphone again, press the option key 'Off' (13).

### 6.11 Pause key

If you dial a telephone number and you would like to add a pause to this number, press the Pause key 'P' (6) at the desired place in the number.

When you dial or redial this number, the pause (3 seconds) is automatically included.

### 6.12 Locating a misplaced handset (paging)

If you cannot find the handset, briefly press the Paging key (15) on the base unit.



All handsets subscribed on the base unit will ring so you can locate the misplaced handset.



To stop the signal, briefly press the Line key (2) on any handset.

### 6.13 Using the alphanumeric handset keypad

Use the alphanumeric keypad to type text. To select a letter, press the corresponding key.

E.g. if you press the alphanumeric key '5', the first character 'j' appears on the display. Press it repeatedly to select other characters from this key.

Press the '2' key once to select the letter 'a'. If you would like to select both 'a' and 'b' after each other, first press the '2' key once to select 'a', wait 2 seconds until the cursor moves to the next position and then press the '2' key twice to select 'b'. You can delete characters mistakenly typed by using the Delete  key (13). The character in front of the cursor will be deleted. All characters can be deleted by pressing the Delete  key (13) for 1,5 seconds.

You can move the cursor by pressing the Up and Down keys  (3) /  (10).

You can switch between upper and lower case by pressing and holding the \*-key (9). The upper left corner will show 'a' for lower case and 'A' for upper case.

**Available characters**

Press the following keys to get below characters:

**Lower case input**

	1x	2x	3x	4x	5x	6x	7x	8x	9x	10x	11x	12x	13x	14x	15x
<b>1</b>	Space	1	€	£	\$	¥	¤								
<b>2 ABC</b>	a	b	c	2	ä	á	à	â	ã	ç					
<b>3 DEF</b>	d	e	f	3	ë	é	è	ê							
<b>4 GHI</b>	g	h	i	4	ï	í	ì	î							
<b>5 JKL</b>	j	k	l	5											
<b>6 MNO</b>	m	n	o	6	ö	ñ	ó	ò	ô	õ					
<b>7 PQRS</b>	p	q	r	s	7	ÿ									
<b>8 TUV</b>	t	u	v	8	ü	ú	ù	û							
<b>9 WXYZ</b>	w	x	y	9	ý	æ	ø	â							
<b>0</b>	.	,	?	!	0	+	-	:	¿	¡	“	’	;	_	
<b>*</b>	*	/	(	)	<	=	>	%							
<b>#</b>	#	@	\	&	§										

**Upper case input**

	1x	2x	3x	4x	5x	6x	7x	8x	9x	10x	11x	12x	13x	14x	15x
<b>1</b>	Space	1	€	£	\$	¥	¤								
<b>2 ABC</b>	A	B	C	2	Ä	Á	À	Â	Ã	Ç					
<b>3 DEF</b>	D	E	F	3	Ë	É	È	Ê							
<b>4 GHI</b>	G	H	I	4	Ï	Í	Ì	Î							
<b>5 JKL</b>	J	K	L	5											
<b>6 MNO</b>	M	N	O	6	Ö	Ñ	Ó	Ò	Ô	Õ					
<b>7 PQRS</b>	P	Q	R	S	7	ß									
<b>8 TUV</b>	T	U	V	8	Ü	Ú	Ù	Û							
<b>9 WXYZ</b>	W	X	Y	Z	9	Ý	Æ	Ø	Å						
<b>0</b>	.	,	?	!	0	+	-	:	¿	¡	“	’	;	_	
<b>*</b>	*	/	(	)	<	=	>	%							
<b>#</b>	#	@	\	&	§										



**6.14 Setting the ring volume level on the handset**

You can change the ring volume of an incoming call (internal and external) between 0-5.

If you select level 'Off' (level 0), the symbol 📞 appears on the display. The handset will not ring when a call is received (the handset will always ring for internal calls).

Level '5' is the highest level. The telephone is set to level '5' by default.

**6.14.1 Setting the ring volume for Internal and external calls (0-5)**

- Press the option button under 'Menu' (13)
- Press the Up or Down key ▲ (3)/▼ (10) repeatedly until 'Handset' is selected
- Press  (13) to confirm
- Press the Up or Down key ▲ (3)/▼ (10) repeatedly until 'Ringer volume' is selected
- Press  (13) to confirm
- The current volume is shown and hearable.
- Press the Up or Down key ▲ (3)/▼ (10) repeatedly to select the desired volume.
- Press 'Save' (13) to confirm your selection or press  (13) to leave the menu.







- You can turn the handset ring volume off during ringing by pressing the option key 'Quiet'.
- By pressing the \* key (9) for 3 seconds you can disable the handset ringer. The \* symbol will appear on the display. To re-activate, press \* key (9) again for 3 seconds

**6.15 Setting the ringer melody on the handset**

You can change the ringer melody for an incoming call (internal or external). The unit has 9 ringer melodies to choose from (1-9). By default, the external ringer melody is set to '3' and the internal ring melody = '2'.

**6.15.1 Setting a ringer melody for internal or external calls (1-9)**

- Press the option button under 'Menu' (13)
- Press the Up or Down key ▲ (3)/▼ (10) repeatedly until 'Handset' is selected
- Press  (13) to confirm
- Press the Up or Down key ▲ (3)/▼ (10) repeatedly until 'Ringtone' is selected
- Press  (13) to confirm
- Select 'External' or 'Internal' and press  (13)
- The current melody is shown and hearable.
- Press the Up or Down key ▲ (3)/▼ (10) repeatedly to select the desired melody.
- Press 'Save' (13) to confirm your selection or press  (13) to leave the menu

**6.16 Locking the key pad**



If you lock the keypad, it is impossible to dial a telephone number. You can only answer incoming calls.

The keypad lock symbol  will appear on the display.

- Press and hold the # key (5) for 3 seconds.
- 'Keypad locked' will appear on the display.
- Press 'Unlock' (13) followed by ' #' (5) Key to unlock the keypad again.



### 6.17 Turning key click ON/OFF

You can set the handset to make a beep whenever you press a key.

- Press the option button under '**Menu**' (13)
- Press the Up or Down key ▲ (3)/▼ (10) repeatedly until '**Handset**' is selected
- Press  (13) to confirm
- Press the Up or Down key ▲ (3)/▼ (10) repeatedly until '**Keypad Beep**' is selected
- Select
  - '**ON**': turn on key click
  - '**OFF**': turn off key click
- Press '**Save**' (13) to confirm your selection or press  (13) to leave the menu.



### 6.18 Display contrast

To change the display contrast:

- Press the option button under '**Menu**' (13)
- Press the Up or Down key ▲ (3)/▼ (10) repeatedly until '**Handset**' is selected
- Press  (13) to confirm
- Press the Up or Down key ▲ (3)/▼ (10) repeatedly until '**Contrast**' is selected
- Select the contrast with the Up or Down key ▲ (3)/▼ (10)
- Press '**Save**' (13) to confirm your selection or press  (13) to leave the menu.



### 6.19 Changing the handset name

You can change the handset name displayed on the handset during standby (max. 15 characters).

- Press the option button under '**Menu**' (13)
- Press the Up or Down key ▲ (3)/▼ (10) repeatedly until '**Handset**' is selected
- Press  (13) to confirm
- Press the Up or Down key ▲ (3)/▼ (10) repeatedly until '**Handset name**' is selected
- Press  (13) to confirm
- Press  (13) to delete each letter of the name and use the alphanumeric keypad to enter the correct name.
- Press '**Save**' (13) to set the new handset name.

### 6.20 Auto answer

When there is an incoming call and the handset is on the base, the phone automatically takes the line when lifted. This function can be turned on or off.

- Press the option button under '**Menu**' (13)
- Press the Up or Down key ▲ (3)/▼ (10) repeatedly until '**Handset**' is selected
- Press  (13) to confirm
- Press the Up or Down key ▲ (3)/▼ (10) repeatedly until '**Autotalk**' is selected
- Press  (13) to confirm
- Select **On** or **Off** and press '**Save**' (13) to confirm



## 7 Default handset settings (Handset reset)

You can restore all handset settings back to default and erase all phonebook, call log, VIP list and redial entries.

### The default settings are:













Base Select:	Auto select
Key Beep:	On
External Melody:	Melody 3
Internal Melody:	Melody 2
Ringer Volume:	Volume 5
Earpiece Volume:	Volume 3
Handsfree:	Volume 3
LCD Contrast:	5
Time Format:	24 hours
Handset Name:	Handset
Phone Book:	Empty
Call log:	Empty
VIP List:	Empty
Redial list:	Empty
Auto Answer:	Off

### To restore the settings:

- Press the redial key  6 for about 10 seconds until 'Handset reset?' appears
- Press  13 to confirm or  13 to stop

## 8 Setting the clock and alarm

### 8.1 Date and time

- Press the option button under 'Menu'  13
- Press the Up or Down key  3 /  10 repeatedly until 'Alarm/Clock' is selected
- Press  13 to confirm
- Press the Up or Down key  3 /  10 repeatedly until 'Date and time' is selected
- Press  13 to confirm
- Enter the last 2 digits of the year and press 'Save'  13
- Enter the month and press 'Save'  13
- Enter the day and press 'Save'  13
- Enter the hours and press 'Save'  13
- Enter the minutes and press 'Save'  13





**When you turn the handset off or when you remove the batteries, you have to set the date and time again!**



**If you have Caller id on your telephone line and the operator sends date and time, your clock will be set automatically on an incoming call.**

## 8.2 Hour format



- Press the option button under **'Menu'** (13)
- Press the Up or Down key ▲ (3)/▼ (10) repeatedly until **'Alarm/Clock'** is selected
- Press  (13) to confirm
- Press the Up or Down key ▲ (3)/▼ (10) repeatedly until **'Set time format'** is selected
- Press  (13) to confirm
- Select the time format (12h or 24h notation) and press **'Save'** (13)

## 8.3 Using the alarm feature

Set the date and time and use your handset to give you a reminder alarm. You can have different alarm settings for each handset registered to your base. The alarm rings only at the handset, not at the base or any other handset.

If one of the alarms is set, the alarm set icon  appears in standby mode on the display.

### 8.3.1 Set the alarm

- Press the option button under **'Menu'** (13)
- Press the Up or Down key ▲ (3)/▼ (10) repeatedly until **'Alarm/Clock'** is selected
- Press  (13) to confirm
- Press the Up or Down key ▲ (3)/▼ (10) repeatedly until **'Set Alarm'** is selected
- Press  (13) to confirm
- Press the Up or Down key ▲ (3)/▼ (10) repeatedly and select one of the 4 types of settings: **Once**, **On Daily**, **Mon to Fri** or **OFF**. Confirm with  (13). If you choose **Once**, **On Daily** or **Mon to Fri** the display will show:

<b>TIME (24hr):</b> 07:00
------------------------------

Enter the time when you want the telephone to ring and confirm by pressing **'Save'** (13).



Press the Up or Down key ▲ (3)/▼ (10) repeatedly and select one of the 9 alarm melodies and confirm by pressing **'Save'** (13).

- To deactivate the Alarm function, select **'Off'** and confirm with  (13).

## 9 The phone book

The phonebook allows you to memorise 200 telephone numbers and names. You can enter names of up to 17 characters length and numbers of up to 24 digits length.



### 9.1 Adding a number and a name to the phone book

- Press the phonebook option key  (13).
- If no entries are stored in the phonebook memory, **'New Entry'** is shown. Press  (13) to add a new entry.





OR

- Press **'Option'** (13) and then  (13) to add a new entry.
- **'Name'** appears on the display. Enter the name using the alphanumeric keys (4).
- Press **'Save'** (13) and enter the telephone number.
- Press **'Save'** (13) to store the record in the phonebook or press **'Esc'** (8) to stop.



## 9.2 Looking up a number in the phone book

- Press the phonebook option key  (13).
- Enter the first letter of the desired name via the alphanumeric keypad (4).
- The first name in the list with this letter appears on the display.
- Press the Up or Down key ▲ (3)/▼ (10) to browse for other numbers in the Phone Book.
- If the desired number appears on the display, the number will be automatically dialled once the Line key  (2) is pressed.

## 9.3 Changing a name or number in the phone book

- Press the phonebook option key  (13).
- Enter the first letter of the desired name.
- The first name in the list with this letter appears on the display.
- Press the Up or Down key ▲ (3)/▼ (10) to browse and select the entry in the Phone Book.
- Once the desired number appears on the display, press 'Option' (13).
- Press the Up or Down key ▲ (3)/▼ (10) and select 'Edit entry'.
- Press  (13) to confirm.
- Press  (13) to delete each letter of the name and use the alphanumeric keypad to enter the correct name.
- Press 'Save' (13).
- Press  (13) to delete each number one by one and use the keypad to enter the correct number.
- Press 'Save' (13) to save the changes made.



## 9.4 Deleting name and number from the phone book



- Once the desired number appears on the display, press 'Option' (13).
- Press the Up or Down key ▲ (3)/▼ (10) and select 'Delete entry'.
- Press  (13) when 'Delete name ?' appears to confirm, or press  (13) to stop.

## 10 VIP list



The VIP list contains phonebook records which are easily reachable by pressing the **VIP**-key (8). Each VIP entry can have its own ring melody. You can copy up to 10 entries from the phonebook to the VIP list.

### 10.1 Copy phonebook entries to the VIP list



- Press the **VIP** key (8).
  - If no entries are stored in the VIP list, 'New Entry' is shown. Press  (13) to add a new entry.
- OR
- Press 'Option' (13) and then  (13) to add a new entry.
  - The phonebook entries are shown.
  - Enter the first letter of the desired name via the alphanumeric keypad.

- The first name in the list with this letter appears on the display.
- Press the Up or Down key ▲ (3)/▼ (10) to browse for other numbers in the Phone Book. Entries which are already stored in the VIP list are indicated with the  icon and can't be copied.
- Once the desired number appears on the display, press 'Select' (13).
- The current melody number is shown. Use the Up or Down key ▲ (3)/▼ (10) to select another melody (1-9) and press  (13) to confirm.

### 10.2 Changing a ring tone for a VIP entry

- Press the **VIP** key (8).
- Press the Up or Down key ▲ (3)/▼ (10) until the desired entry is shown
- Press 'Option' (13) and select 'Ringtone' and then  (13).
- The current melody number is shown. Use the Up or Down key ▲ (3)/▼ (10) to select another melody (1-9) and press  (13) to confirm.



### 10.3 Deleting an entry from the VIP list

- Once the desired number appears on the display, press 'Option' (13).
- Press the Up or Down key ▲ (3)/▼ (10) and select 'Delete entry'.
- Press  (13) when 'Delete name ?' appears to confirm, or press  (13) to stop.



## 11 Base operation

### 11.1 Setting the ring volume and melody of the base

#### 11.1.1 Setting the base melody



- Press the option button under 'Menu' (13)
- Press the Up or Down key ▲ (3)/▼ (10) repeatedly until 'Base settings' is selected
- Press  (13) to confirm
- Press the Up or Down key ▲ (3)/▼ (10) repeatedly until 'Ringtone' is selected
- Press  (13) to confirm
- The current melody is shown and hearable.
- Press the Up or Down key ▲ (3)/▼ (10) repeatedly to select the desired melody (1-5).
- Press 'Save' (13) to confirm your selection or press  (13) to leave the menu

#### 11.1.2 Setting the base ring volume

- Press the option button under 'Menu' (13)
- Press the Up or Down key ▲ (3)/▼ (10) repeatedly until 'Base settings' is selected
- Press  (13) to confirm
- Press the Up or Down key ▲ (3)/▼ (10) repeatedly until 'Ringer volume' is selected
- Press  (13) to confirm
- The current volume is shown and hearable.
- Press the Up or Down key ▲ (3)/▼ (10) repeatedly to select the desired volume (0-5).
- Press 'Save' (13) to confirm your selection or press  (13) to leave the menu.

## 11.2 The R key (flash)



Press the Flash key 'R' (8) to use certain services on your external line such as "call waiting" (if your telephone company offers this feature); or to transfer calls if you use a telephone exchange (PABX). The Flash key 'R' is a brief interruption of the line. You can set the flash time to 100ms or 250ms. Default it set to 100ms by default! However, if your system requires a longer flash time, you can change:

- Press the option button under **'Menu'** (13)
- Press the Up or Down key ▲ (3)/▼ (10) repeatedly until **'Base Settings'** is selected
- Press  (13) to confirm
- Press the Up or Down key ▲ (3)/▼ (10) repeatedly until **'Recall'** is selected
- Press  (13) to confirm
- Press the Up or Down key ▲ (3)/▼ (10) repeatedly to select the desired flash time:
  - **Long** = 250ms
  - **Short** = 100ms
- Press **'Save'** (13) to confirm your selection or press  (13) to leave the menu

## 11.3 Changing the PIN code (system pin code)

Certain functions are only available if you know the PIN code of the base.

The PIN code has 4 digits. The default PIN code setting is '0000'. If you would like to change the default PIN code and set your own secret code, do the following:



- Press the option button under **'Menu'** (13).
- Press the Up or Down key ▲ (3)/▼ (10) repeatedly until **'Base Settings'** is selected
- Press  (13) to confirm
- Press the Up or Down key ▲ (3)/▼ (10) repeatedly until **'System Pin'** is selected
- Press  (13) and enter the old pin code.
- Press **'Save'** (13). If the wrong pin code is entered, **'Incorrect pin'** is shown. If the correct pin code is entered the phone will ask you to enter the new pin. Enter the new system pin code and press **'Save'** (13).
- Enter the new pin code again to confirm and press **'Save'** (13).

## 11.4 Setting the dialling mode

There are two types of dialling modes that can be used on a telephone line:

- DTMF/Tone dialling (the most common)
- Pulse dialling (for older installations)

To change the dialling mode:

- Press the option button under **'Menu'** (13)
- Press the Up or Down key ▲ (3)/▼ (10) repeatedly until **'Base Settings'** is selected
- Press  (13) to confirm
- Press the Up or Down key ▲ (3)/▼ (10) repeatedly until **'Dial mode'** is selected
- Press  (13) and select the dial mode with the up and down keys ▲ (3)/▼ (10) and press **'Save'** (13) to confirm.



## 12 Additional handsets and bases









You can subscribe up to 5 handsets on one base. Each handset can register to 4 base stations and the user can select which base he wants to use.

### 12.1 Adding a new handset



**This is only needed when you have deregistered a handset or when you bought a new one**

Keep the Paging key  (15) on the base unit pressed for 10 seconds until The Line/Handset indicator  (14) on the base unit begins to blink rapidly. The Line/Handset indicator  (14) will blink rapidly for 3 minutes. During these 3 minutes, the base unit is in subscribing mode and you must do the following to subscribe the handset:

- Press the option button under 'Menu' (13).
- Press the Up or Down key  (3) /  (10) repeatedly until 'Registration' is selected
- Press  (13) to confirm
- Select 'Register' and press  (13).
- Select a base (1-4) with the up and down keys  (3) /  (10) and press  (13).
- Enter the system pin code (base pin code) and press  (13).
- The handset will now search for a base and register when found. The standby screen will appear when successfully registered and handset name and number will be shown.







**Each handset can be subscribed to 4 different DECT base units. Each base unit is assigned a number from 1 to 4 in the handset. When you subscribe a new handset, you can assign a base unit number. It is best to use '1'.**

### 12.2 Removing a handset

It is possible to cancel subscription of a handset to a base. You should do this if a handset is damaged and has to be replaced by a new one.



**You can only cancel subscription of another handset, not the handset you are using to do the remove procedure.**



- Press the option button under 'Menu' (13)
- Press the Up or Down key  (3) /  (10) repeatedly until 'Registration' is selected
- Press  (13) to confirm
- Select 'De-registert' and press  (13).
- Enter the system pin code (base pin code) and press  (13).
- Select a handset you wish to remove by pressing the numerical keys (1-5)
- Press 'OK' (13) to remove.

## 12.3 Selecting a base unit

If your handset is subscribed to several base unit stations (max. 4) , you must select a base unit because the handset can only communicate with one base unit at a time. There are two possibilities:



### 12.3.1 Automatic selection

If you set the handset to 'automatic selection', the handset will automatically choose the closest base unit in standby.

- Press the option button under '**Menu**' (13).
- Press the Up or Down key ▲ (3)/▼ (10) repeatedly until '**Handset**' is selected
- Press  (13) to confirm
- Press the Up or Down key ▲ (3)/▼ (10) repeatedly until '**Select Base**' is selected
- Press  (13) to confirm
- Select '**Auto**' and press  (13) to confirm.

### 12.3.2 Manual selection

If you set the handset to 'manual selection', the handset will only choose the base unit you have set.

- Press the option button under '**Menu**' (13).
- Press the Up or Down key ▲ (3)/▼ (10) repeatedly until '**Handset**' is selected
- Press  (13) to confirm
- Press the Up or Down key ▲ (3)/▼ (10) repeatedly until '**Select Base**' is selected
- Press  (13) to confirm
- Select '**Manual**' and press  (13) to confirm.
- Select the base with the Up and Down key ▲ (3)/▼ (10) and press '**Save**' (13).



**Before you can select a base unit, the handset must be subscribed to the base first.**

## 12.4 Using multiple handsets







**These functions are only possible when more than 1 handset is subscribed to the base.**

### 12.4.1 Calling another handset

- Press the INT key (12).
- '**Handset \_**' appears on the display
- Dial the number of the handset you would like to call.
- After finishing your call, press the Line key  (2) to hang up.



### 12.4.2 Receiving an internal call

- The internal call icon  and the number of the handset calling, appear on the display.
  - Press the Line key  (2) to accept the internal call.
- OR
- Lift the handset off its base(if the Auto answer option is active,see §“6.20 Auto answer” )

- During the call, the handset number of the caller and the symbol  appear on the display.
- After finishing your call, press the Line key  ② to hang up.

#### **12.4.3 Receiving an external call during an internal call**

If you receive an external call during an internal call, you will hear a call waiting tone (double beep) on both handsets being used for an internal call.



- Press the Line key  ② twice to accept the external call.
- After finishing your call, press the Line key  ② to hang up.

#### **12.4.4 Transferring a call to another handset**

- You have an external caller on the line.
- Press the INT key ⑫. "Handset \_" appears on the display.
- Dial the number of the handset to which you would like to transfer the call.
- If the handset dialled is answered, you can have an internal conversation. Press the Line key  ② and the external call is transferred.
- If the handset dialled is not answered, press the option key 'END' ⑬ to speak to the external caller again.

#### **12.4.5 Conference call (two internal handsets and one external caller)**

You can have a telephone conversation with one internal and one external caller at the same time.



- While on the line with an external caller, press the INT key ⑫. The external line is put on hold and the  icon appears on the display.
- Dial the number of the handset you would like to include in the call. You can toggle between Internal and External line by pressing the INT-key ⑫. When the 2nd handset is put on hold while talking with the external line the  icon appears on the display.
- Once the handset dialled is answered, press the option key 'Conf.' ⑬.
- Now you are connected to one external and one internal caller (conference call).

## **13 Caller ID/CLIP**





**This service only works when you have a Caller ID/Clip subscription.  
Contact your telephone company for more information.**

When you receive a call, the telephone number of the caller, the date and time appears on the handset display. If the name is programmed in the Phone Book, the name in the Phone Book is displayed!

The telephone can store 30 calls in a Call List that can be reviewed later. When the memory is full, the new calls automatically replace the oldest calls in the memory. The symbol  on the display blinks if there are calls not answered in the call list. If the Call List is empty and you press the Up key  ③, 'Call list empty' will be shown.

You can view the information of an incoming call:

- Press the Up key ▲ (3). The name (if sent by the network or present in the Phone Book memory) of the caller will be shown on the first line. The telephone number of the caller on the 2nd line and date and time on the 3rd line. At the end of the 3rd line you also have the indication of the following:
  -  Unread or unanswerd call
  -  Read or answered call

### 13.1 The Call List

The calls received are stored in the Call List (max. 30 numbers).

- Briefly press the Up key ▲ (3) to view the most recent call.
- The name of the most recent caller appears on the display. If no name is available, '**NO NAME**' appears on the first line.
- The date and time the call was received are linked to each call.
- Press the Up key ▲ (3) to browse other numbers on the list.



- **If neither the Up or Down key ▲ (3)/▼ (10) is pressed for 15 seconds, the telephone will return to standby mode.**
- **After a call is received, the number of the caller remains on the display for 15 seconds after the last ring.**
- **Caller ID is not available while you are on the line with a caller and there is a second incoming call.**

### 13.2 Calling a number from the Call List

- Press the Up key ▲ (3) to go into the Call List
- Press the Up key ▲ (3) to look up the desired number.
- Once the number is on the display, press the Line key  (2) and the number is dialed automatically.

### 13.3 Storing a number from the Call List in the Phone Book

- Press the Up key ▲ (3) to go to the Call List.
- Press the Up key ▲ (3) to look up the desired number.
- Press '**Option**' (13).
- Press the Up or Down key ▲ (3)/▼ (10) repeatedly until '**Save number**' is selected
- Press  (13) to confirm.
- The name will be shown if the name was send by the network. You can edit or add a name before saving.
- Press '**Save**' (13) to go to the telephone number. Edit the number if needed and press '**Save**' (13) again to store the entry into the phonebook
- The telephone returns to the call list.

### 13.4 Deleting numbers from the Call List

#### 13.4.1 Deleting one number

- Press the Up key ▲ (3) to go to the Call List.



- Press the Up key ▲ (3) to look up the desired number.
- Press 'Option' (13).
- Press the Up or Down key ▲ (3)/▼ (10) repeatedly until 'Delete call' is selected
- Press  (13) to confirm
- The call is deleted and the next call appears on the display.

#### 13.4.2 Delete all numbers

- Press the Up key ▲ (3) to go to the Call List.
- Press the Up key ▲ (3) to look up the desired number.
- Press 'Option' (13).
- Press the Up or Down key ▲ (3)/▼ (10) repeatedly until 'Delete all calls' is selected
- Press  (13) to confirm
- All calls are deleted.

## 14 Voice mail indicator

This function only works if you have the voice mail or phone mail service and if the network sends this indication along with the caller ID (CLIP) information!

When you receive a new message in your voice mail system, the  icon will appear on the display. Once you have listened to your messages, the  icon will disappear.

## 15 Menu structure

Level 1	Level 2	Level 3	Level 4	Level 5	Level 6	Level 7	Level 8
Menu	Handset	Ringtone	External	Melody 1-9			
			Internal	Melody 1-9			
		Ringer Volume	Off				
			Volume 1-5				
		Handset Name					
		Keypad Beeps	On				
			Off				
		Display Contrast	Level 1-8				
		Autotalk	On				
			Off				
		Select Base	Auto				
			Manual	Basis 1-4			
		Language	Deutsch				
			English				
			Español				
			Nederlands				
			Français				
	Base settings	Ringtone	Melody 1-9				
		Ringer Volume	Volume 0-5				
		Dial Mode	Tone				
			Pulse				
		Flash	Short				
			Long				
		System PIN	Old PIN	New Code	Again		
	Alarm/Clock	Set Alarm					
		Date and Time	Year	Month	Day	Hour	Minute
		Set Time Format	24 Hour				
			12 Hour				
	Registration	Register	Select Base	System PIN :			
		De-register	System PIN :	Select Handset			
	Power off						

## 16 Trouble shooting

Symptom	Possible cause	Solution
No display	Batteries uncharged	Check the position of the batteries Recharge the batteries
	Handset turned OFF	Turn ON the handset
No tone	Telephone cord badly connected	Check the telephone cord connection
	The line is occupied by another handset	Wait until the other handset hangs up
The icon  flashes	Handset out of range	Bring the handset closer to the base
	The base has no power supply	Check the mains connection to the base
	The handset is not registered to the base	Register the handset to the base
Base or handset do not ring	The ringing volume is zero or low	Adjust the ringing volume
Tone is good, but there is no communication	The dialling mode is wrong	Adjust the dialling mode (pulse/tone)
Telephone does not react to pressing the keys	Manipulation error	Remove the batteries and but them back in place
	Keypad lock ON	Turn OFF the Keypad Lock
Flash (R) Key does not work	Wrong Flash time	Change the flash time setting

## 17 Technical characteristics

Standard:	<b>DECT</b> (Digital Enhanced Cordless Telecommunications) <b>GAP</b> ( Generic Access Profile )
Frequency range:	1880 MHz to 1900 MHz
Number of channels:	120 duplex channels
Modulation:	GFSK
Speech coding:	32 kbit/s
Emission power:	10 mW ( average power per channel )
Range:	300 m in open space /50 m maximum inhouse
Base power supply:	In: 230 VAC / 50 Hz / 50mA Out: 9VDC / 500mA / 4.5 VA
Handset Batteries:	2 rechargeable batteries AAA, NiMh
Handset standby time:	110 hours in standby
Handset talk time:	12 hours
Charging time:	6-8 hours
Normal conditions of use:	+5 °C to +45 °C
Dialling mode:	Pulse / Tone
Flash time:	100 or 250 ms

## 18 Warranty

### 18.1 Warranty period

The Ucom units have a 36-month warranty period. The warranty period starts on the day the new unit is purchased. The warranty on batteries is limited to 6 months after purchase. Consumables or defects causing a negligible effect on operation or value of the equipment are not covered.

The warranty has to be proven by presentation of the original purchase receipt, on which the date of purchase and the unit-model are indicated.

### 18.2 Warranty handling

A faulty unit needs to be returned to a Ucom service centre including a valid purchase note. If the unit develops a fault during the warranty period, Ucom or its officially appointed service centre will repair any defects caused by material or manufacturing faults free of charge. Ucom will at its discretion fulfil its warranty obligations by either repairing or exchanging the faulty units or parts of the faulty units. In case of replacement, colour and model can be different from the original purchased unit.

The initial purchase date shall determine the start of the warranty period. The warranty period is not extended if the unit is exchanged or repaired by Ucom or its appointed service centres.

### 18.3 Warranty exclusions

Damage or defects caused by incorrect treatment or operation and damage resulting from use of non-original parts or accessories not recommended by Ucom are not covered by the warranty.

Ucom cordless phones are designed to work with rechargeable batteries only. The damage caused by the use of non-rechargeable batteries is not covered under warranty.

The warranty does not cover damage caused by outside factors, such as lightning, water and fire, nor any damage caused during transportation.

No warranty can be claimed if the serial number on the units has been changed, removed or rendered illegible.

Any warranty claims will be invalid if the unit has been repaired, altered or modified by the buyer or by unqualified, non-officially appointed Ucom service centres.

## 19 Service address and support

Please see extra paper (Service address and support numbers) or [www.ucom.be](http://www.ucom.be).

## 20 Declaration of Conformity and manufacturer

Topcom Europe Nv.  
Grauwmeer 17  
3001 Heverlee  
Belgium



## DECLARATION OF CONFORMITY

We, Topcom Europe Nv, Grauwmeer 17 , 3001 Heverlee , Belgium, declare that our product :

**Model type: UCOM Cocoon 910**

is in compliance with the essential requirements and other relevant provisions of the R&TTE directive 1999/5/EC and carries the CE mark accordingly.

Supplementary information:

The product complies with the requirements of:

- EN60950
- EN 301489-01
- EN 301489-06
- EN 301406

Date: 06/07/2005  
Place: Heverlee , Belgium  
Name: Verheyden Geert  
Function: Technical Director

Signature:



European contact: Topcom Europe Nv, R&D department, Research Park, Grauwmeer 17, 3001 Heverlee, Belgium. Tel : +32 16 398920 , Fax : +32 16 398939

**Cocoon 910**

visit our website  
**[www.ucom.be](http://www.ucom.be)**

U8006483