

UCOM

COCOON 970 SIM



User Guide

v 1.5



Before Initial use

Thank you for purchasing this new digital cordless telephone

Intended Purpose:

This product is intended to be connected indoor to a analogue telephone line.

You have acquired a Cocoon 970, which is a product made in accordance with the Digital Enhanced Cordless Telecommunications (DECT). DECT technology is characterized by high-security protection against interceptions as well as high-quality digital transmission. This telephone was designed for a wide range of applications. For example, this telephone can be used within a network of base units and handsets, constituting a telephone system which:

- Operates up to 5 handsets at one base unit.
- Allows an intercom between 2 handsets.
- Allows the operation of a handset at up to 4 base units.

Caller ID is a network provider service. After subscribing to Caller ID, this phone will display the caller's phone number.

Important

To use 'Caller ID' (display caller), this service has to be activated on your phone line. Normally you need a separate subscription from your telephone company to activate this function. If you don't have the Caller ID function on your phoneline, the incoming telephone numbers will NOT be shown on the display of your telephone.

To be connected to the public analogue telephone network.

The features described in this manual are published with reservation to modifications.

The CE symbol indicates that the unit complies with the essential requirements of the R&TTE directive.

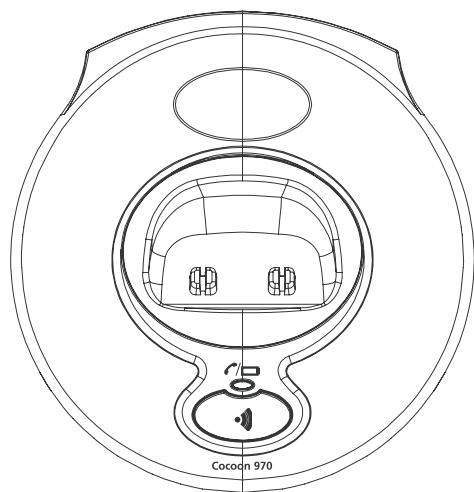
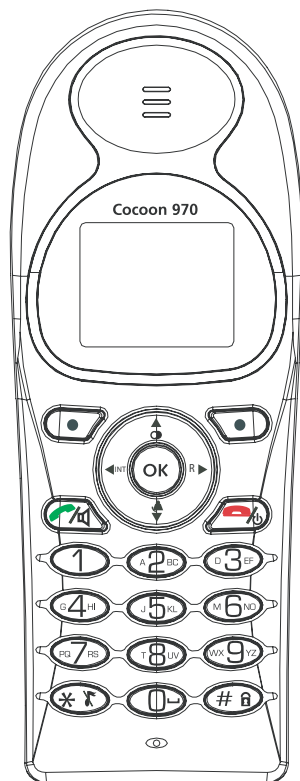

1	Safety advice	1
2	Getting started	2
2.1	How to use this user guide.....	2
2.2	Installing the base	2
2.3	Installing the handset.....	3
2.4	Keys/Led.....	4
2.5	Symbols	4
2.6	Display keys	5
2.7	Base LED.....	5
2.8	Navigating the menu.....	5
2.9	Menu overview	6
3	Using the telephone	6
3.1	Switching the handset ON/OFF.....	6
3.2	Changing the menu language	6
3.3	Making a normal telephone call	7
3.4	Receiving a telephone call	7
3.5	Handsfree mode.....	8
3.6	Adjust earpiece/handsfree volume	8
3.7	Secrecy function (Mute function).....	8
3.8	Locating a handset (Paging function).....	8
3.9	Keypad Lock	8
3.10	Using the alphanumerical keypad	8
4	Phonebook	9
4.1	To add an entry.....	9
4.2	To dial an entry.....	9
4.3	Show Details.....	9
4.4	Delete an entry or all entries.....	10
4.5	Edit name and number	10
4.6	Copy a phonebook entry to another handset	10
4.7	Copy all phonebook entries to another handset.....	11
5	Sim card copy	11
5.1	SIM country code settings	11
5.2	Copy SIM card entries to the handset.....	12
6	Caller Identification	15
6.1	Normal incoming PSTN calls.....	15
7	Personalise the handset	16
7.1	Ringtone and volume.....	16
7.2	Handset name	17
7.3	Keypad beeps.....	17
7.4	Wallpaper	17
7.5	Menu color.....	17
7.6	Setting the contrast	17
7.7	Autotalk	18
7.8	Prefix code.....	18
7.9	Using the alarm feature	18
7.10	Setting the date and time	19
7.11	Setting the time format	19

8	Base settings	19
8.1	Ringtone	19
8.2	Ringer Volume	19
8.3	Dial Mode.....	19
8.4	Recall (Flash).....	20
8.5	System PIN.....	20
9	Tools.....	20
9.1	Appointment.....	20
9.2	Stopwatch	21
10	Additional handsets and base stations	21
10.1	Adding a new handset	21
10.2	Removing a handset	22
10.3	Select a base	22
10.4	Using the intercom feature	22
11	Troubleshooting	23
12	Technical dataTechnical characteristics.....	24
13	Warranty	25
13.1	Warranty period.....	25
13.2	Warranty handling	25
13.3	Warranty exclusions	25
14	Disposal of the device (environment)	25
15	Cleaning	25

1 Safety advice

The following safety advice must always be followed before using electrical equipment. Please read carefully through the following information concerning safety and proper use. Make yourself familiar with all the functions of the equipment. Be careful to keep these advice notes and if necessary pass them on to a third party.

Electrical safety and protection:

- Do not operate the equipment if the mains plug, cable or the equipment itself is damaged.
- If the equipment is dropped, then it must be checked by an electrician before further use.
- Dangerous voltages are present inside the equipment. Never open the housing or insert objects through the ventilation holes.
- Do not allow liquids to get into the equipment. In case of emergency, pull out the plug from the socket.
- Similarly, if a fault develops during use or before you start to clean the equipment, pull the plug out if the socket.
- Do not touch the charger and plug contacts with sharp or metal objects.
- Do not carry out any modifications or repairs to the equipment yourself. Have repairs done to the equipment or the mains cable only by a specialist service centre. Unsatisfactory repairs can lead to considerable danger for the user.
- Children frequently underestimate the dangers associated with electrical equipment. Therefore you must never leave children unsupervised in the vicinity of electrical equipment.
- The equipment is not to be used in a damp room (e.g. bathrooms) or rooms where there is a lot of dust.
- Equipment connected to the mains during a thunderstorm can be damaged by lightning. Therefore you should pull the plug out of the mains socket during a storm.
- To completely disconnect the equipment from the electricity supply, the plug must be removed from the socket. When doing this always pull on the plug itself and never on the cable.
- Protect the mains cable from hot surfaces or other sources of damage and do not allow it to become constrained.
- Check the mains cable regularly for any damage.
- Unwind the mains cable completely before use.
- Make sure that the mains cable does not represent a trip hazard.
- The operation of some medical devices may be affected.
- The handset may cause an unpleasant buzzing sound in hearing aids.

Fire safety:

- The heat accumulated inside the equipment can lead to the defect and/or to the fire of the equipment. Do not expose this equipment therefore to extreme temperature like:
 1. direct sun exposure and heater warmth
 2. ventilation holes may not be covered

Danger of explosion:

- Never throw batteries in fire.

Poisoning danger:

- Keep batteries away from small children.

Note:

- Only use the charger plug supplied. Do not use other chargers, as this may damage the batteries cells.
- The wall outlet for the power supply must be close and accessible.
- Only use rechargeable batteries of the same type. Place the batteries with correct polarity inside the battery compartment (polarity is marked inside the handset). Never use normal unrechargeable batteries!



As this telephone cannot be used in case of a power cut, you should use a mains-independent telephone for emergency calls, e.g. a mobile phone.

2 Getting started

2.1 How to use this user guide

In this user guide, following method is used to clarify the instructions:

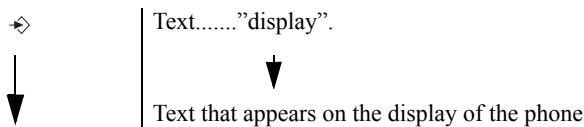

Key to press. This key can be a soft key (See "2.6 Display keys"). When the soft key is a symbol, it is shown in the left column. When the soft key is text, the left or right soft key is shown in the left column and the text is shown in the right column between quotation marks.

2.2 Installing the base

For installation, do the following:

- 1 Plug one end of the adaptor into the outlet and the other end into the adaptor jack on the back of the base.
- 2 Connect one end of the telephone cord with the wall phone jack and the other end to the bottom of the base.
- 3 Put the telephone- and AC power line cord in the base guides as shown on picture 2A.

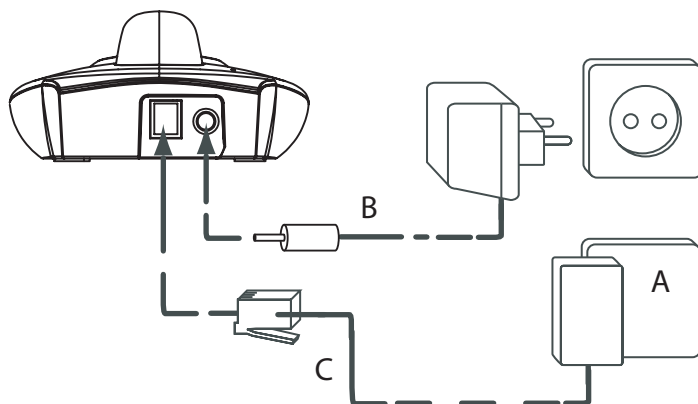

- 2A Back view of base -

- A. Telephone wall outlet
- B. Power cable
- C. Telephone cord

2.3 Installing the handset

- 1 Open the battery compartment as shown on picture 2B.
- 2 Insert the batteries respecting the polarity (+ and -).
- 3 Close the battery compartment.
- 4 Leave the handset on the base unit for 20 hours. The Line/Charge indicator  on the base will light up.

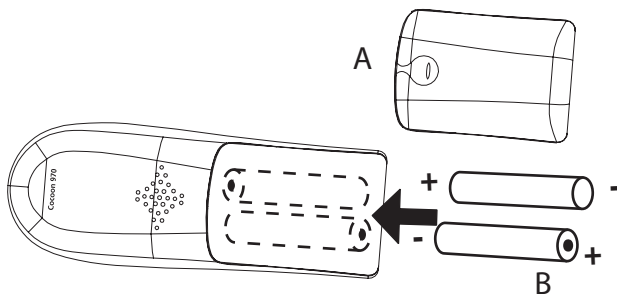

- 2B Back view of handset -

- A. Cover
- B. Rechargeable batteries



Before you use the telephone for the first time, you must first make sure the battery is charged for 20 hours. If you do not do this, the telephone will not work optimally.

2.4 Keys/Led

Handset

1. Display
2. Up/Redial key
3. Right soft menu key
4. Right/Flash key
5. On-hook / OFF key
6. Alphanumeric keys
7. Keypad lock
8. Ringer Off-key
9. Down/call log key
10. Off-hook key/ Handsfree/ On-key
11. Left/INT key
12. OK key
13. Left soft menu key

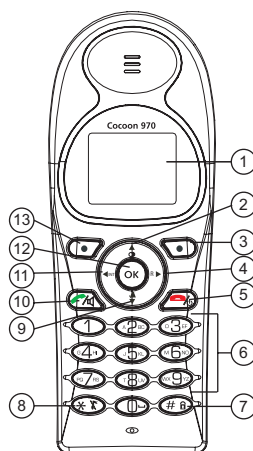

- 2C Handset -





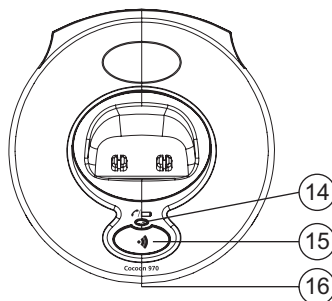









Base

14. In use/Power/Handset on base LED
15. Paging key
16. SIM card holder



- 2D Base -

2.5 Symbols

	Off hook		Keypad lock
	On hook		Alarm set
	Missed calls in call list*		Handset not registered or out of range
	Handset ringer volume OFF		Battery empty
	Handset within base range		Battery low
	Internall Call		Battery medium
	Handsfree		Battery full
	New voice mail		

* If the Caller line identification service is available on the telephone line.

2.6 Display keys

Display-keys (softkeys) are located directly under the display. The function of these 2 keys changes depending on the operation mode. The actual function is displayed as icon or text directly above the 2 display keys.

	Phonebook		Mute
	OK/Confirm		Back
	Menu		No key
	Delete		





2.7 Base LED

The LED (14) indicates the following status:



- OFF: no base power connected or handset not in base for charging
- ON: handset charging
- Blinking slowly: Off hook or during ringing
- Blinking rapidly: during registration

2.8 Navigating the menu





The Cocoon 970 has a menu system which is easy to use. Each menu leads to a list of options. The menu map is shown on the following paragraph.

- | | |
|---|--|
|  | 1 When the handset is switched on and in standby, press the left soft menu key  to open the main menu. |
|  | 2 Scroll to the desired menu option. |
|  | 3 Press the soft menu key to view further options or to confirm the setting displayed. |

To exit or to go back one level in the menu

- | | |
|--|---|
|  | To go to the previous level in the menu, press the soft menu key. |
|  | To cancel and return to standby at any time, press the on-hook key. |

2.9 Menu overview

Menu	Submenu items
	Handset Ringtone Ringer Volume Handset Name Keypad Beep Wallpaper Menu Color Contrast Auto Talk Prefix Select Base Language Registration
	Base settings Ringtone Ringer volume Dial mode Recall System PIN
	Alarm/Clock Set Alarm Date & Time Time Format
	Tools Appointment Stopwatch
	Power Off

3 Using the telephone

3.1 Switching the handset ON/OFF



- 1 Press and hold the OFF key to switch the handset off.
- 2 Press the off-hook key or place the handset in the base to switch the handset back on.

3.2 Changing the menu language



- 1 Enter the menu.
- 2 Select “Handset” and confirm.
- 3 Select “Language” and confirm.
- 4 Select a language and confirm.
The screen displays “Saved”.
- 5 Press the on-hook key to return to standby.



The ↻ arrows indicate that further options are available in the menu.

3.3 Making a normal telephone call

Direct dialling



- 1 Press the off-hook key to start the call.
- 2 Dial the telephone number.
- 3 Press the on-hook key to hang up or put the handset back on the base.

Pre-dialling

With the pre-dialling feature, you can enter and modify a number before making the call.



- 1 Dial a number of up to 24 digits.
Press and hold the 0 key to insert a pause. The screen displays a “P”.
- 2 Press the soft menu key to correct.
- 3 Press the off-hook key to start the call.
- 4 Press the on-hook key to hang up or put the handset back on the base.

Redial a number from the list

You can redial up to 10 of the last numbers called. If you have stored a name in the phonebook to go with the number, the name will be displayed instead.



- 1 Press the redial key.
- 2 Select a number. If the number is in the phonebook, the name will be shown.
- 3 Press the off-hook key to start the call or select “Option”.
- 4 If you selected “Option”, scroll and select:
“Delete Call”: to remove the number from the call list;
“Save Number”: to store the number into the phonebook;
“Delete All”: to erase the call list.
- 5 Confirm selection.
- 6 Press the on-hook key to return to standby.

3.4 Receiving a telephone call

When you receive an external call, the screen displays “External Call”.

To take the call:



- 1 Press the off-hook key.
OR
Lift the handset off its base if you have activated “Auto Talk”
(See ”7.7 Autotalk”)
The call in progress icon  appears on the screen. The call duration is displayed after 15 seconds.
- 2 Press the on-hook key to hang up or put the handset back on the base.



You can turn the ring volume off during incoming call by selecting “Quiet”.

3.5 Handsfree mode

Handsfree lets you talk to your caller without holding the handset. It also enables other people in the room to listen to both sides of your conversation.



- 1 To switch any call to handsfree, press the handsfree key during the call.

3.6 Adjust earpiece/handsfree volume



- 1 Press up or down to select volume 1-5 during a normal or handsfree call.

3.7 Secrecy function (Mute function)

To turn off the microphone so the person on the other side of the line will not hear you.



- 1 During a conversation, press the soft menu key to deactivate the microphone.

“Mute On” appears on the display.



- 2 Select “Off” to activate the microphone again.

3.8 Locating a handset (Paging function)



- 1 Press the paging key on the base.

All handsets registered with the base will ring for 30 seconds.



- 2 Press any key on the handset to stop the paging.

3.9 Keypad Lock

To lock the keypad to prevent accidental dialling while carrying the handset around.

In standby:



- 1 Press and hold the keypad locked key (key 7 - Picture 2C) until “Locked” and the keypad locked icon  appears on the display.



- 2 To unlock, select “Unlock”, followed by the keypad locked key.

3.10 Using the alphanumerical keypad

With your telephone, you can also enter alphanumeric characters. This is useful for entering a name into the phonebook, giving a name to the handset, ...





To select a letter, press the corresponding key as many times as necessary.

For example, to select an ‘A’, press ‘2’ once. To select a ‘B’, press ‘2’ twice and so on.

To select ‘A’ and then ‘B’ consecutively, press ‘2’ once, wait until the cursor moves on to the next character, then press ‘2’ twice.

During entering text, the available character under each key appears below on the display.











You can change the input character set from English (abc) to Latin (aâá), Greek (ΑΒΓ) or Russian (АБВ) by pressing and holding the #-key for 2 seconds.

	Press '0' to select a space.
	Press the *-key to switch between small letters and capitals.
	Press and hold the #-key for 2 seconds to change the input character set.
	Press the soft menu key to correct.





4 Phonebook

Each handset can store up to 200 names and numbers. Names can be up to 16 characters long and numbers up to 24 digits.







4.1 To add an entry

	1 Press the soft menu key.
	If the phonebook is empty, "Phonebook Empty" appears on the display. If names have been stored, they are listed.
	2 Select "Option".
 	3 Select "New Entry" and confirm.
 	4 Use the keypad to enter the name, then select "Save".
 	5 Use the keypad to enter the number, then select "Save".
 	6 Select the desired ring melody and select "Save".
	7 Return to standby.











4.2 To dial an entry

	1 Press the soft menu key.
	2 Select the desired name or use the keypad to enter the first letter of the name.
	3 Press the off-hook key to start the call.
	4 Return to standby.











4.3 Show Details

	1 Press the soft menu key.
	2 Select the desired name or use the keypad to enter the first letter of the name.
	3 Select "Option".
 	4 Select "Show Details" and confirm.
	The name, number and ring melody you have assigned to the entry appear on the display.
	5 Return to standby.











4.4 Delete an entry or all entries

- | | | |
|---|----------|--|
|  | 1 | Press the soft menu key. |
|  | 2 | Select the desired name or use the keypad to enter the first letter of the name. |
|  | 3 | Select "Option". |
| To delete one entry: | | |
|   | 4 | Select "Delete Entry" and confirm. |
| To delete all entries: | | |
|   | 4 | Select "Delete All" and confirm. |
|   | 5 | Press the left menu key to cancel or the right menu key to confirm. |
|  | 6 | Return to standby. |

4.5 Edit name and number

- | | | |
|---|----------|--|
|  | 1 | Press the soft menu key. |
|  | 2 | Select the desired name or use the keypad to enter the first letter of the name. |
|  | 3 | Select "Option". |
|   | 4 | Select "Edit Entry" and confirm. |
|  | 5 | Press the soft menu key to delete and use the keypad to change the name. |
|  | 6 | Select "Save". |
|  | 7 | Edit the number and select "Save". |
|   | 8 | Select the desired ring melody and select "Save". |
|  | 9 | Return to standby. |

4.6 Copy a phonebook entry to another handset

- | | | |
|---|----------|--|
|  | 1 | Press the soft menu key. |
|  | 2 | Select the desired name or use the keypad to enter the first letter of the name. |
|  | 3 | Select "Option". |
|   | 4 | Select "Copy Entry" and confirm. |
| The available handsets (all the handsets that are registered on the base) are shown. | | |
|   | 5 | Select the desired handset and confirm. |
| "Copying to handset x" appears on the display. | | |
| "Receive phonebook record?" appears on the display of the destination handset. | | |
|   | 6 | On the destination handset, press the right menu key to confirm or the left menu key to cancel the transfer. |
|  | 7 | Return to standby. |

4.7 Copy all phonebook entries to another handset



By copying all entries from one handset to another, you will erase all existing records at the destination handset.



1 Press the soft menu key.



2 Select the desired name or use the keypad to enter the first letter of the name.



3 Select "Option".



4 Select "Copy All" and confirm.

The available handsets (all the handsets that are registered on the base) are shown.



5 Select the desired handset and confirm.

"Copying to handset x" appears on the display.

"Replace all phonebook records?" appears on the display of the destination handset.



6 On the destination handset, press the right menu key to confirm or the left menu key to cancel the transfer.



7 Return to standby.

5 Sim card copy



Only 3V compatible sim cards can be used.

5.1 SIM country code settings

All numbers stored on your mobile phone SIM card can be copied to your Cocoon 970 SIM. These numbers can be converted to make sure that they are applicable for your local PSTN line. Four codes can be entered to guarantee a correct conversion:

- **IDD CODE:** This code is dialled before the country code. In most countries "00" will be used. The Cocoon will store the numbers beginning with "+" as numbers beginning with "00" in the phonebook of the Cocoon 970.
- **COUNTRY CODE:** Set you own country code. If you enter your own country code, the Cocoon will remove the country code from all the numbers in the SIM beginning with this code when copying to phonebook.
- **AREA CODE:** In some countries you don't need to dial the area code for local calls. In this case you need to enter your area code so that the numbers will be stored without this code.
- **PABX CODE:** If your Cocoon will be connected to a PABX system you need to enter the number to be dialled to get the public PSTN line. In most cases this will be a "0" or a "9".









If your PABX system is an analogue type, a pause needs to be added to the public line code. For example: "0P" or "9P".

Please look into the examples below to understand the conversion of the numbers.

Numbers stored on SIM	International code (IDD)	Country code	Area Code	PABX code	Number stored in phonebook
0032123456	00	32	016	-	0123456
0032163456	-	32	016	-	3456
+32123456	-	32	016	-	0123456
+32123456	00	-	012	0	00032123456
+49789456	00	32	016	-	0049789456
0032163456	00	49	016	-	0032163456
0032123456	00	32	12	-	3456
0032163456	00	49	016	-	0032163456
+32123456	00	32	12	0P	0P456
+49789456	00	46	-	-	0049789456
016123456	00	32	12	-	016123456
16123456	00	32	12	-	16123456

To program the different codes:

-  **1** Press the soft menu key.
-  **2** Select "Option".
-  **3** Select "SIM COPY" and confirm.
-  **4** Select "DIAL CODES" and confirm.
-  **5** Scroll and select:
 "IDD CODE": to set the internal dial code
 "COUNTRY": to set the country code
 "AREA CODE": to set the area code
 "PABX CODE": to set the PABX code
-  **6** Confirm selection and enter the code as above explained.
-  **7** Return to standby.

5.2 Copy SIM card entries to the handset



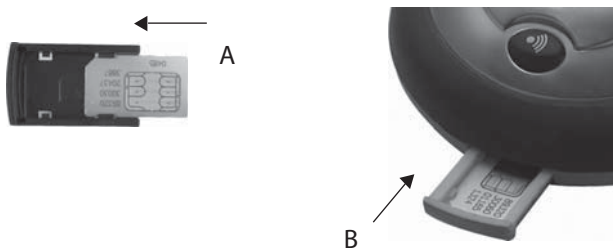





You can copy phonebook entries from a mobile phone SIM cards (only 3V SIM cards). The SIM phonebook is copied to the handset you are using. Before you start copy from SIM card, please make sure you have programmed the correct country codes (See "5.1 SIM country code settings"). Insert the SIM card into the slot on the base as shown in figure 5.



- 5 Base with SIM-card reader -

A. Insert the SIM-card into the reader

B. Insert the reader into the base





- | | |
|---|--|
| 

 
 

 | <ol style="list-style-type: none"> 1 Press the soft menu key. 2 Select "Option". 3 Select "SIM COPY" and confirm. 4 Select "SIM TO PHONE" or "PHONE TO SIM" and confirm. 5 Scroll and select:
 "COPY ENTRY": To copy a single entry
 "APPEND": To add the records
 "COPY ALL": To copy all records and overwrite all existing records 6 Confirm selection. 7 Return to standby. |
|---|--|



During some of above operation the following can appear on the screen:

- "NO ENTRIES": When the SIM card is empty*
- "EMPTY BK": When phonebook is empty*
- "SIM FULL": When SIM card is full during copy from handset to SIM*
- "NO CARD": When there is no SIM card in base or when it's unreadable*
- "WRONG PIN": When you have entered the wrong PIN code. You have 3 changes to enter the PIN code, after the 3rd time the SIM card will be locked, you need to use another device like a mobile phone to unlock it.*
- "SORTING": When SIM card entries are downloaded into the phone memory.*

Copy a single record from SIM to handset

- | | |
|---|---|
|  | <ol style="list-style-type: none"> 1 Carry out above procedure and select "SIM TO PHONE" and select "COPY ENTRY". |
|   | <ol style="list-style-type: none"> 2 If the SIM card is PIN protected, you have to enter your SIM PIN code first and confirm.
 "Sorting" will appear when entries from the Sim card are copied to the phone. |
|   | <ol style="list-style-type: none"> 3 Enter the first character or scroll to the name you want to copy and select "Option". |



- 4 Select:
“Show details” to see the name and telephone number
“Copy” to copy this entry into the handset phonebook



- 5 Confirm selection.



- 6 Return to standby.

Copy a single record from Handset to SIM



- 1 Press the soft menu key.



- 2 Enter the first character or scroll to the name you want to copy and select “Option”.



- 3 Select “SIM COPY” and confirm.



- 4 Select “PHONE TO SIM” and confirm.



- 5 Select “COPY ENTRY” and confirm.

- 6 If the SIM card is PIN protected you have to enter your SIM PIN code first and confirm.

“Sorting” will appear when entries from the Sim card are copied to the phone.



- 7 Return to standby.

Copy all SIM records to the handset phonebook



- 1 Press the soft menu key.



- 2 Select “Option”.



- 3 Select “SIM COPY” and confirm.



- 4 Select “SIM TO PHONE” and confirm.



- 5 Select “COPY ALL” and confirm.

The phone will ask to confirm to overwrite + amount of records.



- 6 Confirm selection.



- 7 Return to standby.

Copy all handset records to the SIM card



- 1 Press the soft menu key.



- 2 Select “Option”.



- 3 Select “SIM COPY” and confirm.



- 4 Select “PHONE TO SIM” and confirm.



- 5 Select “COPY ALL” and confirm.

The phone will ask to confirm to overwrite + amount of records.



- 6 Confirm selection.



- 7 Return to standby.







Add SIM records to the handset phonebook











- 1 Press the soft menu key.



- 2 Enter the first character or scroll to the name you want to copy and select “Option”.

-  **3** Select “SIM COPY” and confirm.
 -  **4** Select “SIM TO PHONE” and confirm.
 -  **5** Select “APPEND” and confirm.
 -  **6** If the SIM card is PIN protected you have to enter your SIM PIN code first and confirm.
- The amount of records that will be overwritten is displayed.
-  **7** Confirm selection.
 -  **8** Return to standby.

Add handset phonebook records to SIM card

-  **1** Press the soft menu key.
 -  **2** Enter the first character or scroll to the name you want to copy and select “Option”.
 -  **3** Select “SIM COPY” and confirm.
 -  **4** Select “PHONE TO SIM” and confirm.
 -  **5** Select “APPEND” and confirm.
 -  **6** If the SIM card is PIN protected you have to enter your SIM PIN code first and confirm.
- The amount of records that will be overwritten is displayed.
-  **7** Confirm selection.
 -  **8** Return to standby.

6 Caller Identification

6.1 Normal incoming PSTN calls



This service only works when you have a Caller ID/Clip subscription. Please contact your telephone company.



When you receive a call from your fixed telephone line, the telephone number of the caller appears on the handset display. The telephone can receive calls in both FSK and DTMF. You can also see his or her name if it is transmitted by the network. If the name is programmed in the phonebook, the name in the phonebook is displayed!











The telephone can store 30 calls in a Call List (received and missed) that can be reviewed later. When the memory is full, the new calls automatically replace the oldest calls in the memory.



Missed calls are signalled by a blinking icon on the display. The handset name is replaced by this icon and the amount of missed calls.

To read the received calls

-  **1** Press the down button.
- The Received calls list appears on the display. This is a combination of received and missed calls.
-  **2** Select the desired name or number.







- | | |
|---|---|
|  | 3 Press the off-hook key to start the call. |
| | OR |
|  | Select "Option". |
| | To delete one entry: |
|  | 4 Select "Delete Entry" and confirm. |
|  | 5 Return to standby. |
| | To delete all entries: |
|  | 5 Select "Delete All" and confirm. |
|  | 6 Return to standby. |
| | To add the number to the phonebook: |
|  | 5 Select "Add Entry" and confirm. |
|  | 6 Use the keypad to enter the name, then select "Save". |
|  | 7 Use the keypad to edit the number, then select "Save". |
|  | 8 Select the desired ring melody and select "Save". |
|  | 9 Return to standby. |

7 Personalise the handset

7.1 Ringtone and volume







Ringtone

You can choose from 18 different ringer melodies for internal and external calls.

- | | |
|---|---|
|  | 1 Enter the menu. |
|  | 2 Select "Handset" and confirm. |
|  | 3 Select "Ringtone" and confirm. |
|  | 4 Select "External" for external calls or select "Internal for internal calls and confirm. |
|  | 5 Select the desired melody and confirm. |
| | During scrolling the melody is played. |
|  | 6 Return to standby. |









Ringer volume

You can choose from 5 handset ringer volume levels and off.









- | | |
|---|---|
|  | 1 Enter the menu. |
|  | 2 Select "Handset" and confirm. |
|  | 3 Select "Ringer volume" and confirm. |
| | The current setting is displayed. |
|  | 4 Press the up key to increase the volume. |
|  | 5 Press the down key to decrease the volume. |
|  | 6 Select "Save" to confirm. |
|  | 7 Return to standby. |

7.2 Handset name

You can change the name displayed on the handset during standby (max. 9 characters).









- | | | |
|---|---|-------------------------------------|
|  | 1 | Enter the menu. |
|   | 2 | Select "Handset" and confirm. |
|   | 3 | Select "Handset name" and confirm. |
|  | 4 | Enter the name you want. |
|  | 5 | Press the soft menu key to correct. |
|  | 6 | Select "Save" to confirm. |
|  | 7 | Return to standby. |

7.3 Keypad beeps









- | | | |
|---|---|-----------------------------------|
|  | 1 | Enter the menu. |
|   | 2 | Select "Handset" and confirm. |
|   | 3 | Select "Keypad beep" and confirm. |
|   | 4 | Select "On" or "Off" and confirm. |
|  | 5 | Return to standby. |

7.4 Wallpaper









You can choose from 3 different wallpaper pictures which appear in the background during standby.

- | | | |
|---|---|--|
|  | 1 | Enter the menu. |
|   | 2 | Select "Handset" and confirm. |
|   | 3 | Select "Wallpaper" and confirm. |
|   | 4 | Select the picture you want and confirm. |
| | | During scrolling a sample is played. |
|  | 5 | Return to standby. |

7.5 Menu color









- | | | |
|---|---|--|
|  | 1 | Enter the menu. |
|   | 2 | Select "Handset" and confirm. |
|   | 3 | Select "Menu color" and confirm. |
|   | 4 | Select "Blue", "Green" or "Red" and confirm. |
|  | 5 | Return to standby. |

7.6 Setting the contrast

- | | | |
|---|---|---|
|  | 1 | Enter the menu. |
|   | 2 | Select "Handset" and confirm. |
|   | 3 | Select "Contrast" and confirm. |
|   | 4 | Select the contrast you want (1-8) and confirm. |
|  | 5 | Return to standby. |















7.7 Autotalk

When there is an incoming call and the handset is on the base, the phone automatically takes the line when lifted from the base. This function can be turned on or off.

- | | | |
|---|----------|-----------------------------------|
|  | 1 | Enter the menu. |
|   | 2 | Select “Handset” and confirm. |
|   | 3 | Select “Autotalk” and confirm. |
|   | 4 | Select “On” or “Off” and confirm. |
|  | 5 | Return to standby. |

7.8 Prefix code















It is possible to use your telephone with a prefix number. When dialling telephone numbers, you can add automatically the prefix code before the number.

- | | | |
|---|----------|--|
|  | 1 | Enter the menu. |
|   | 2 | Select “Handset” and confirm. |
|   | 3 | Select “Prefix” and confirm. |
|   | 4 | Select “Edit” and confirm. |
|   | 5 | Enter the prefix code, e.g. ‘0’ and select “Save”. |
| | | OR |
|   | 4 | Select “On/Off” and confirm. |
|   | 5 | Select “On” or “Off” and confirm. |
|  | 6 | Return to standby. |









7.9 Using the alarm feature

You can have a different alarm setting for each handset registered to your base. The alarm rings only at the handset, not at the base or any other handset.









Set the alarm

- | | | |
|---|----------|---|
|  | 1 | Enter the menu. |
|   | 2 | Select “Alarm/Clock” and confirm. |
|   | 3 | Select “Set alarm” and confirm. |
|   | 4 | Select “Once”, “On daily”, “Mon to Fri” or “Off” and confirm.
If you have selected “Once”, “On daily” or “Mon to Fri”, the display will show:
Time (24Hr):
00:00 |
|   | 5 | Enter the time you want the telephone to ring and confirm with “Save”. |
|   | 6 | Select the desired ringtone and confirm with “Save”. |
|   | 7 | To deactivate the alarm, select “Off” and confirm. |
|  | 8 | Return to the previous menu. |

7.10 Setting the date and time

- | | | |
|---|---|--|
|  | 1 | Enter the menu. |
|   | 2 | Select “Alarm/Clock” and confirm. |
|   | 3 | Select “Date & Time” and confirm. |
|   | 4 | Enter year, month, day, time and minutes and select “Save” to confirm. |
|  | 5 | Return to the previous menu. |









7.11 Setting the time format

- | | | |
|---|---|--|
|  | 1 | Enter the menu. |
|   | 2 | Select “Alarm/Clock” and confirm. |
|   | 3 | Select “Time format” and confirm. |
|   | 4 | Select “12Hrs” or “24Hrs” and confirm. |
|  | 5 | Return to the previous menu. |

8 Base settings









8.1 Ringtone

You can choose from 9 different ringer melodies.

- | | | |
|---|---|--|
|  | 1 | Enter the menu. |
|   | 2 | Select “Base Settings” and confirm. |
|   | 3 | Select “Ringtone” and confirm. |
|   | 4 | Select the desired melody and confirm. |
| | | During scrolling a sample is played. |
|  | 5 | Return to standby. |

8.2 Ringer Volume

You can choose from 5 handset ringer volume levels.









- | | | |
|---|---|--|
|  | 1 | Enter the menu. |
|   | 2 | Select “Base Settings” and confirm. |
|   | 3 | Select “Ringer Volume” and confirm. |
| | | The current setting is displayed. |
|  | 4 | Press the up key to increase the volume. |
|  | 5 | Press the down key to decrease the volume. |
|  | 6 | Select “Save” to confirm. |
|  | 7 | Return to standby. |

8.3 Dial Mode

There are 2 types of dialling mode:









- DTMF/Tone dialling (most common used)
- Pulse dialling (for older installations)

To change the dialling mode:

- | | | | |
|---|--|----------|---|
|  | | 1 | Enter the menu. |
|   | | 2 | Select “Base Settings” and confirm. |
|   | | 3 | Select “Dial mode” and confirm. |
|   | | 4 | Select “Tone” or “Pulse” and select “Save”. |
|  | | 5 | Return to standby. |











8.4 Recall (Flash)

Press the Flash key “R” (Key 4 - Picture 2C) to use certain services on your external line such as “call waiting” (if your phone company offers this feature); or to transfer calls if you use a telephone exchange (PABX). The Flash key “R” is a brief interruption of the line. You can set the flash time to 100ms or 250ms.

- | | | | |
|---|--|----------|---|
|  | | 1 | Enter the menu. |
|   | | 2 | Select “Base Settings” and confirm. |
|   | | 3 | Select “Recall” and confirm. |
|   | | 4 | Select short flash time (100ms) or long flash time (250ms) and select “Save”. |
|  | | 5 | Return to standby. |

8.5 System PIN











The System PIN is used for registering and deregistering handsets and some other optional settings. The default System PIN is 0000.













- | | | | |
|---|--|----------|--|
|  | | 1 | Enter the menu. |
|   | | 2 | Select “Base Settings” and confirm. |
|   | | 3 | Select “System PIN” and confirm. |
|   | | 4 | Enter the old PIN (0000 by default) and select “Save”. |
|   | | 5 | Enter the new PIN, select “Save” and repeat this. |
|  | | 6 | Return to standby. |

9 Tools











9.1 Appointment

You can set 5 appointments or reminders which you can give a name and an alarm by date and time.

- | | | | |
|---|--|----------|---|
|  | | 1 | Enter the menu. |
|   | | 2 | Select “Tools” and confirm. |
|   | | 3 | Select “Appointments” and confirm. |
|   | | 4 | Select one of the 5 appointments and select “Option”. |
| | | | To edit the appointment: |
|   | | 5 | Select “Edit” and confirm. |
|   | | 6 | Edit the name of the appointment and select “Save”. |

- | | | |
|---|---|---|
|  |  | 7 Enter the date of the appointment and select “Save”. |
|  |  | 8 Enter the time and select “Save”. |
|  |  | 9 Select the desired alarm melody and select “Save”. |
|  | | 10 Return to standby. |
| To delete the appointment: | | |
|  |  | 5 Select “Delete” and confirm. |
|  | | 6 Press the right soft menu key to confirm. |
|  | | 7 Press the left soft menu key to go back. |
|  | | 8 Return to standby. |

9.2 Stopwatch

- | | | |
|---|---|---|
|  | | 1 Enter the menu. |
|  |  | 2 Select “Tools” and confirm. |
|  |  | 3 Select “Stopwatch” and confirm. |
|  | | 4 Select “Start” to start the stopwatch. |
|  | | 5 Select “Stop” to stop the stopwatch. |
|  | | Select “Start” again to restart. |
|  | | Select “Reset” to reset the counter. |
|  | | 6 Return to standby. |

10 Additional handsets and base stations



You can subscribe up to 5 handsets on a base. Each handset can register up to 4 base stations and the user can select the base he wants to use.

10.1 Adding a new handset















Only needed when you have deregistered a handset or when you bought a new one.

To put the base into registration mode:













- | | | |
|---|--|--|
|  | | 1 Press and hold the paging key on the base. |
|  | | The LED on the base will start to blink on the base for 90 seconds. During that time, the base is ready to register. |

On the handset:

- | | | |
|---|---|---|
|  | | 1 Enter the menu. |
|  |  | 2 Select “Handset” and confirm. |
|  |  | 3 Select “Registration” and confirm. |
|  |  | 4 Select “Register” and confirm. |
|  |  | 5 Select the number of the base to be associated with the handset (1-4) and confirm. |
|  |  | 6 Enter the system PIN (0000 by default) and confirm. |
|  | | 7 Return to standby. |









10.2 Removing a handset

This procedure needs to be carried out on a different handset than the one you want to remove.

- | | |
|---|---|
|  | 1 Enter the menu. |
|   | 2 Select “Handset” and confirm. |
|   | 3 Select “Registration” and confirm. |
|   | 4 Select “De-Register” and confirm. |
|   | 5 Enter the system PIN (0000 by default) and confirm. |
|   | 6 Enter the handset number that needs to be removed and confirm. |
|  | 7 Return to standby. |

10.3 Select a base

You can switch your handset between bases. You can also set it to automatically base select with the strongest signal. The handset must first be registered with each base individually.



- | | |
|---|---|
|  | 1 Enter the menu. |
|   | 2 Select “Handset” and confirm. |
|   | 3 Select “Select Base” and confirm. |
|   | 4 Select “Manual” or “Auto” and confirm. |
| | If you have selected “Manual”: |
|   | 5 Select the base to be associated with the handset and confirm. |



When you have activated Automatic base selection and the handset is out of range on the current base, the handset will only search for the strongest base in standby (not during communication).



10.4 Using the intercom feature

Calling an internal handset

- | | |
|---|--|
| INT | 1 Press the left key INT.
The screen displays “Handset _”. |
|  | 2 Enter the internal number of the handset you want to call. |
|  | 3 Press the on-hook key to hang up or put the handset back on the base. |

Transfer an external call to another handset

During an external call:

- | | |
|---|---|
| INT | 1 Press the left key INT.
The screen displays “Handset _”. |
|  | 2 Enter the internal number of the handset you want to call.
Your external correspondent is placed on hold. |
|  | 3 When the internal correspondent answers, press the on-hook key to transfer the call. |
| | OR |

INT



- 3 If the internal correspondent doesn't answer, press the left key INT to retrieve the external correspondent or to go from one to the other.
- 4 Press the on-hook key to hang up or put the handset back on the base.

Conference call

You can talk between 2 handsets and an external line at the same time.

During an external call:

INT



INT



- 1 Press the left key INT.
The screen displays "Handset _".
- 2 Enter the internal number of the handset you want to call.
Your external correspondent is placed on hold.
- 3 When the internal correspondent answers, select "Conf.".

OR
- 3 If the internal correspondent doesn't answer, press the left key INT to retrieve the external correspondent.
- 4 Press the on-hook key to hang up or put the handset back on the base.

Taking an external call during an internal communication

When you are on intercom with another handset, you can still pick up outside calls.

To take an incoming call:



- 1 Press the on-hook key. The internal communication is now interrupted.
- 2 Press the off-hook key. You are now in communication with the outside caller.

11 Troubleshooting

Symptom	Possible cause	Solution
No display	Batteries uncharged	Check the position of the batteries
		Recharge the batteries
No tone	Handset turned OFF	Turn ON the handset
	Telephone cord badly connected	Check the telephone cord connection
The icon γ flashes	The line is occupied by another handset	Wait until the other handset hangs up
	Handset out of range	Bring the handset closer to the base
Base or handset do not ring	The base has no power supply	Check the mains connection to the base
	The handset is not registered on the base	Register the handset on the base
	The ringing volume is off or low	Adjust the ringing volume

Symptom	Possible cause	Solution
Not possible to transfer a call on PABX	The Flash Time is too short or too long	Change the Flash Time
Telephone does not react to pressing the keys	Manipulation error	Remove the batteries and put them back in place

12 Technical data Technical characteristics

Standard	DECT (Digital Enhanced Cordless Telecommunications) GAP (Generic Access Profile)
Frequency range	1880 MHz to 1900 MHz
Number of channels	120 duplex channels
Modulation	GFSK
Speech coding	32 kbit/s
Emission power	10 mW (average power per channel)
Range	300m in open space /50m maximum inhouse
Number of handsets	Up to 5
Base powersupply	230V / 50 Hz / 6V DC 300mA
Handset Batteries:	2 rechargeable batteries AAA, NiMh 1,2V, 800mA
Handset autonomy	100 hours in standby
Handset talk time	10 hours
Normal conditions of use	+5 °C to +45 °C
Dialling mode	Pulse / Tone
Flash time	100 or 250 ms
Measurements base	ca. 122mm x 117mm x 59mm (L x B x H)
Measurements handset	ca. 139,5mm x 52,5mm x 29,5mm (L x B x H)
Weight base	ca. 116g
Weight handset with batteries	ca. 116g

13 Warranty

13.1 Warranty period

The Ucom units have a 36-month warranty period. The warranty period starts on the day the new unit is purchased. The warranty on batteries is limited to 6 months after purchase. Consumables or defects causing a negligible effect on operation or value of the equipment are not covered. The warranty has to be proven by presentation of the original purchase receipt, on which the date of purchase and the unit-model are indicated.

13.2 Warranty handling

A faulty unit needs to be returned to a Ucom service centre including a valid purchase note. If the unit develops a fault during the warranty period, Ucom or its officially appointed service centre will repair any defects caused by material or manufacturing faults free of charge. Ucom will at its discretion fulfil its warranty obligations by either repairing or exchanging the faulty units or parts of the faulty units. In case of replacement, colour and model can be different from the original purchased unit.

The initial purchase date shall determine the start of the warranty period. The warranty period is not extended if the unit is exchanged or repaired by Ucom or its appointed service centres.

13.3 Warranty exclusions

Damage or defects caused by incorrect treatment or operation and damage resulting from use of non-original parts or accessories not recommended by Ucom are not covered by the warranty. Ucom cordless phones are designed to work with rechargeable batteries only. The damage caused by the use of non-rechargeable batteries is not covered under warranty.

The warranty does not cover damage caused by outside factors, such as lightning, water and fire, nor any damage caused during transportation.

No warranty can be claimed if the serial number on the units has been changed, removed or rendered illegible.

Any warranty claims will be invalid if the unit has been repaired, altered or modified by the buyer or by unqualified, non-officially appointed Ucom service centres.

14 Disposal of the device (environment)



At the end of the product lifecycle, you should not throw this product into the normal household garbage but bring the product to a collection point for the recycling of electrical and electronic equipments. The symbol on the product, user guide and/or box indicate this.

Some of the product materials can be re-used if you bring them to a recycling point.

By re-using some parts or raw materials from used products you make an important contribution to the protection of the environment. Please contact your local authorities in case you need more information on the collection points in your area.

15 Cleaning

Clean the telephone with a slightly damp cloth or with an anti-static cloth. Never use cleaning agents or abrasive solvents.

DECLARATION OF CONFORMITY

We, Topcom Europe Nv, Grauwmeer 17 , 3001 Heverlee , Belgium, declare that our product :

Model type: UCOM Cocoon 970 SIM

is in compliance with the essential requirements and other relevant provisions of the R&TTE directive 1999/5/EC and carries the CE mark accordingly.

Supplementary information:

The product complies with the requirements of:

- EN60950
- EN 301489-01
- EN 301489-06
- EN 301406

Date: 01/08/2006
Place: Heverlee , Belgium
Name: Verheyden Geert
Function: Technical Director

Signature:

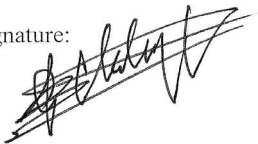

European contact: Topcom Europe Nv, R&D department, Research Park, Grauwmeer 17, 3001 Heverlee, Belgium. Tel : +32 16 398920 , Fax : +32 16 398939

SERVICE RETURN CARD - RÜCKSENDEKARTE -
CARTE DE RETOUR SERVICE - RETOURFICHE

RETURN WITH YOUR DEFECT PRODUCT

Name/Vorname/Prénom/Naam:

Surname/Familiennaam/Nom/Familiennaam:

Street/Straße/Rue/Straat:

Nr./N°:

Box/Postfach/Boîte/Postbus:

Location/Ort./Lieu/Plaats:

Post code/Postleitzahl/Code Postal/Postcode:

Country/Land/Pays/Land:

Tel./Tél.:

E-mail:

Model name/Modellbezeichnung/Nom du modèle/Modelnaam:

Serial Nr./Seriennummer/N° série/Seriennummer:

Purchase date/Kaufdatum/Date d'achat/Aankoopdatum:

 - - (DD/MM/YYYY) - (TT/MM/JJJJ)

Fault description/Beschreibung des Defekts/Description de la panne/Beschrijving defect:

(Original Proof of Purchase has to be attached to this return card to be valid for warranty)

Model name/Modellbezeichnung/Nom du modèle/Modelnaam:

Serial Nr./Seriennummer/N° série/Seriennummer:

Purchase date/Kaufdatum/Date d'achat/Aankoopdatum:

 - - (DD/MM/YYYY) - (TT/MM/JJJJ)

Fault description/Beschreibung des Defekts/Description de la panne/Beschrijving defect:

UCOM

COCOON 970 SIM

MD2500070